

# KS PERMAGLIDE® plain bearings

## Test methods: Machining the sliding layer

The sliding layer of KS PERMAGLIDE® P22 and P202 has a machining allowance of around 0.15 mm. This can be machined by turning, drilling or reaming in order to:

- Achieve smaller clearance tolerances
- Compensate for misalignments.

Tried and tested methods are turning and boring with:

- Dry cutting
- Cutting speeds from 100 to 150 m/min
- Feed rate of 0.05 mm/rev
- Cutting depth of max. 0.1 mm
- Carbide tools (Fig. 1)

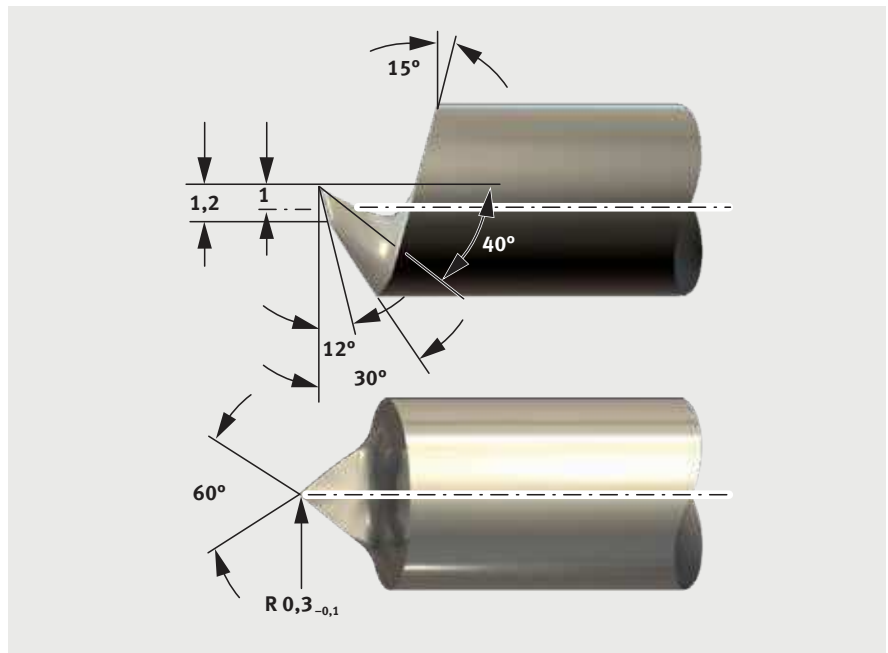

Fig. 1: Cutting tool for KS PERMAGLIDE® P22 and P202

Machining temperatures above 140 °C constitute a health hazard.

P22 chips contain lead.  
Lead is hazardous to health.



**Attention:**

Removing more material reduces service life.



**Attention:**

Inexpert machining will have a negative impact on service life and load-bearing capacity.



**Attention:**

Parts must be cleaned after machining.