



Machining options

Moulded parts and sliding elements from KS PERMAGLIDE® materials

KS PERMAGLIDE® plain bearings are made from metal-plastic composite materials. The combination of steel, non-ferrous metals and polymers creates materials with excellent tribological characteristics. The composite, multi-layered materials have a high rigidity and viscosity thanks to the steel back and very good sliding properties thanks to the sliding layer structure of bronze and polymers.

KS PERMAGLIDE® materials are used to make sheets in thicknesses of 0.5mm to 3 mm on high-volume machines as primary materials. The sheets can be used to make sliding elements from KS PERMAGLIDE® in a wide range of designs using all conventional sheet metal processing methods.

The conventional machining options for KS PERMAGLIDE® materials include

- Cutting blanks, e.g. with a plate shear
- Drilling and sinking, e.g. mounting holes
- Nibbling or punching moulded parts
- Reshaping through bending, edging and deep drawing
- Rolling large bushes
- Shaping through water jet cutting or high precision cutting
- Milling of grooves and recesses

Note:
Caution when cutting at high temperatures!

High temperatures cause burns to the cut surfaces. The carbon deposits can be abrasive! Clean the cut surfaces carefully if necessary.

Note:
Caution during water jet cutting!

The cutting takes place on the jet side to prevent the sliding layer from being washed away.

Motorservice offers a wide range of special shapes to suit your requirements, e.g. for machining moulded parts. Machining is carried out according to the high quality standards of the automotive industry with tolerances in accordance with DIN ISO 3547 or more precise. The Motorservice sales team can advise you on the design, material selection and quality of your other designs.



Other designs made from KS PERMAGLIDE® materials

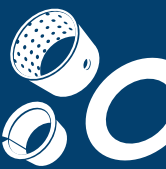

Machining the sliding layer

The sliding layer of KS PERMAGLIDE® P22 and P202 has a machining allowance of around 0.15 mm. This can be machined by turning, drilling or reaming to:

- Achieve smaller clearance tolerances
- Compensate for misalignments

Tried and tested methods are turning and boring with:

- Dry cutting
- Cutting speeds from 100 to 150 m/min
- Feed rate of 0.05 mm/rev
- Cutting depth of max. 0.1 mm
- Hard metal tools



Attention:

- Machining temperatures above 140 °C constitute a health hazard.
- P22 chips contain lead. Lead is hazardous to health.
- Changes in colour may occur on the polymer sliding layer due to high-energy radiation e.g. UV-light. To protect the surfaces, exposure to direct sunlight should be avoided.
- Removing more material reduces service life.
- Inexpert machining will have a negative impact on service life and load bearing capacity.
- Parts must be cleaned after machining.

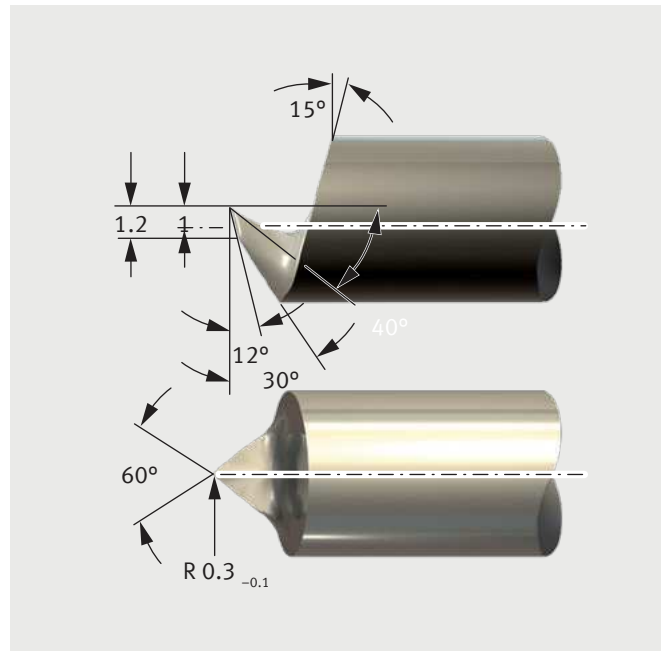

Cutting tool for KS PERMAGLIDE® P22 and P202

Machining the bearing elements

- KS PERMAGLIDE® plain bearings can be cut or can be machined in other ways (e.g. shortening, bending or boring).
- KS PERMAGLIDE® plain bearings should preferably be cut from the PTFE side. The burrs produced during cutting would impair the sliding surface.
- Bearing elements must be cleaned after machining.
- Bare steel surfaces (cut edges) must be protected against corrosion with:
 - Oil, or
 - Galvanic protective layers
 At higher flow densities or with longer coating times, the sliding layers must be covered to prevent deposits.



Attention:

Machining temperatures that exceed the following limits are hazardous to health:
 +280°C for KS PERMAGLIDE® P1
 +140°C for KS PERMAGLIDE® P2
 Chips may contain lead.

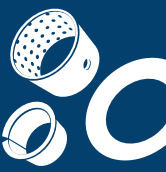

Calibrating the bearing bore after mounting

(Only applies to P1 plain bearings)

Calibration

KS PERMAGLIDE® plain bearings are ready to install on delivery, and should only be calibrated if a bearing clearance with a narrower tolerance cannot otherwise be reached.

Attention:

Calibration considerably shortens the service life of KS PERMAGLIDE® P1 bushes.

The illustration shows calibration using a mandrel.

The table contains standard values for the diameter of the calibrating mandrel d_k . Precise values can only be ascertained through tests.

Better possibilities

The bearing clearance tolerance can be reduced through the following measures, which do not adversely affect service life:

- Narrower tolerances for housing bore
- Narrower shaft tolerances

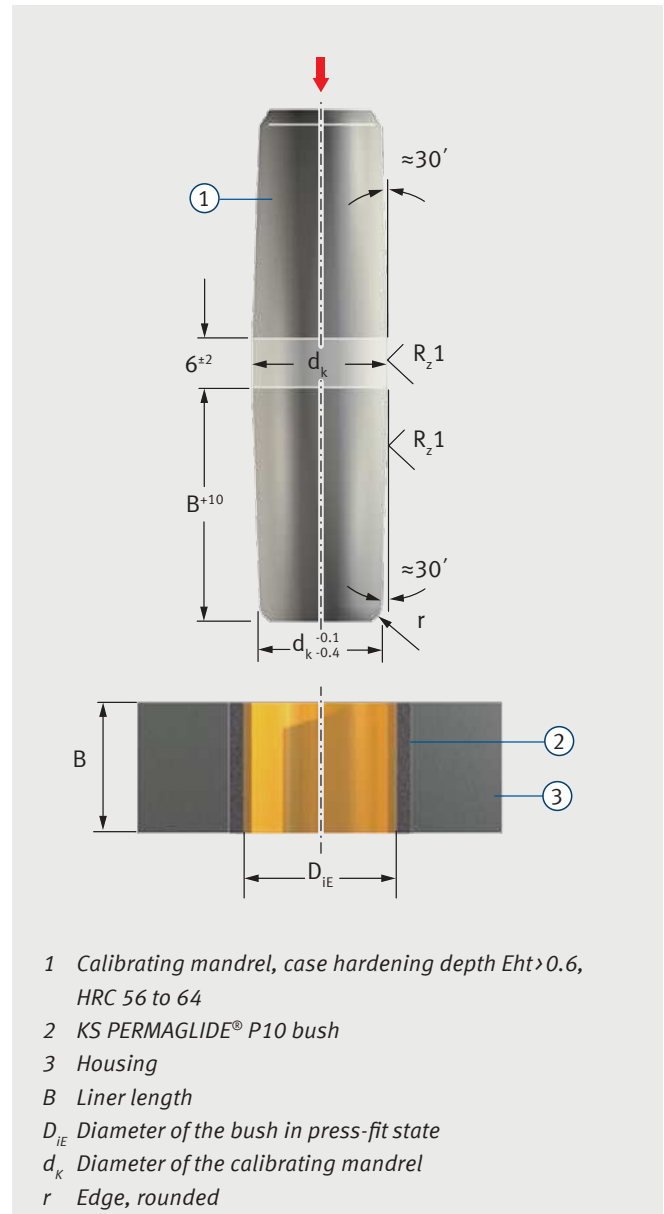

- 1 Calibrating mandrel, case hardening depth $E_{ht} > 0.6$, HRC 56 to 64
 - 2 KS PERMAGLIDE® P10 bush
 - 3 Housing
- B Liner length
 D_{iE} Diameter of the bush in press-fit state
 d_k Diameter of the calibrating mandrel
 r Edge, rounded

Calibration

Desired inside diameter of the bush	Diameter of calibrating mandrel ¹⁾ d_k	Service life ²⁾
D_{iE}	–	100 % L_N
$D_{iE} + 0.02$	$D_{iE} + 0.06$	80 % L_N
$D_{iE} + 0.03$	$D_{iE} + 0.08$	60 % L_N
$D_{iE} + 0.04$	$D_{iE} + 0.10$	30 % L_N

Standard values for the calibrating mandrel diameter and the reduction in service life

D_{iE} Inside diameter of the bush in press-fit state.

¹⁾ Standard value, based on steel housing.

²⁾ Standard value for dry running.